



Mack Anthem





An Australian Legend Reborn.

We took a century of experience building Australia and combined this with the proven design of the American Mack Anthem. The result? The new Mack Anthem built in Australia, for Australia — a truck that will make you rethink what's possible on the highway, at the port or on the construction site. Boldly designed and engineered tough, Anthem is born ready for whatever the road demands.

BUILT FOR YOUR BUSINESS.

Efficient in every sense of the word, Anthem saves on fuel and reduces maintenance costs while maximizing uptime—and your bottom line.

DESIGNED FOR THE DRIVER.

Anthem's cab design and driver environment are built around the way work gets done on the road, keeping drivers comfortable, safe and focused all day long.

Built for your business.

EFFICIENT DESIGN

Anthem's advanced aerodynamics and purpose-built design put function at the forefront and reduce day-to-day costs.

THE STRENGTH OF A LEGEND

Anthem comes standard with our proprietary Mack engines and transmissions, delivering unrivaled performance and fuel efficiency.

DEPENDABLE SUPPORT

From parts and service to our Mack Action Service, Mack has the right combination of people and technology across the largest dealer network, to keep you on the road.

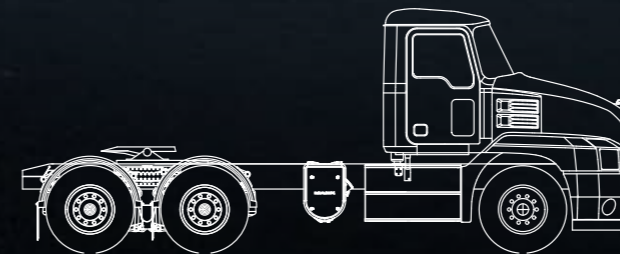

Day Cab



36-inch Stand Up Sleeper

Aerodynamic never looked so Mack.

The new Mack Anthem™ challenges the expectations of aerodynamic design with a bold look that dramatically improves fuel efficiency.



Roof Fairings

Improves airflow from the cab to the trailer.

Bonnet and Fenders

Bonnet slope and fender design directs air over and around the trailer.

Close-Out Flange

Prevents airflow between bonnet and bumper and moves air around the cab.

FUPs

Front Underrun Protection for driver and road-user safety.

Air Dam

Reduces turbulence under the vehicle for less drag.

Covered Tow Loops

Cuts down on wind resistance and creates a clean look.

By displacing air to the sides, as well as over the bonnet and roof, Anthem cuts wind resistance and improves fuel economy.

Built to last.

Mack Anthem drives down operating costs with durability that stands up to the rigors of the road and keeps you out of the shop.



West Coast Side Mirrors

Strong hinges with zero plastic, tougher materials and spring-loaded mounts help keep maintenance costs down.

Durable Components

From bolts to latches, all Anthem components are made from tough, long-lasting materials.

LED Lights

LED headlights are 66% brighter, last longer, use less energy and provide better visibility.

Smart serviceability.

Anthem's tilt-assist bonnet and functional, modular design allow service professionals to access, repair and replace components more quickly.

EFFICIENT ENGINE ACCESS

MP® Series Engines

Single-Point Latch and Tilt Assist

Requires 50% less effort to open for easy access to the engine.

Easy Access for Engine Serviceability

Level Check
Check and top off oil and fluid levels from the ground.

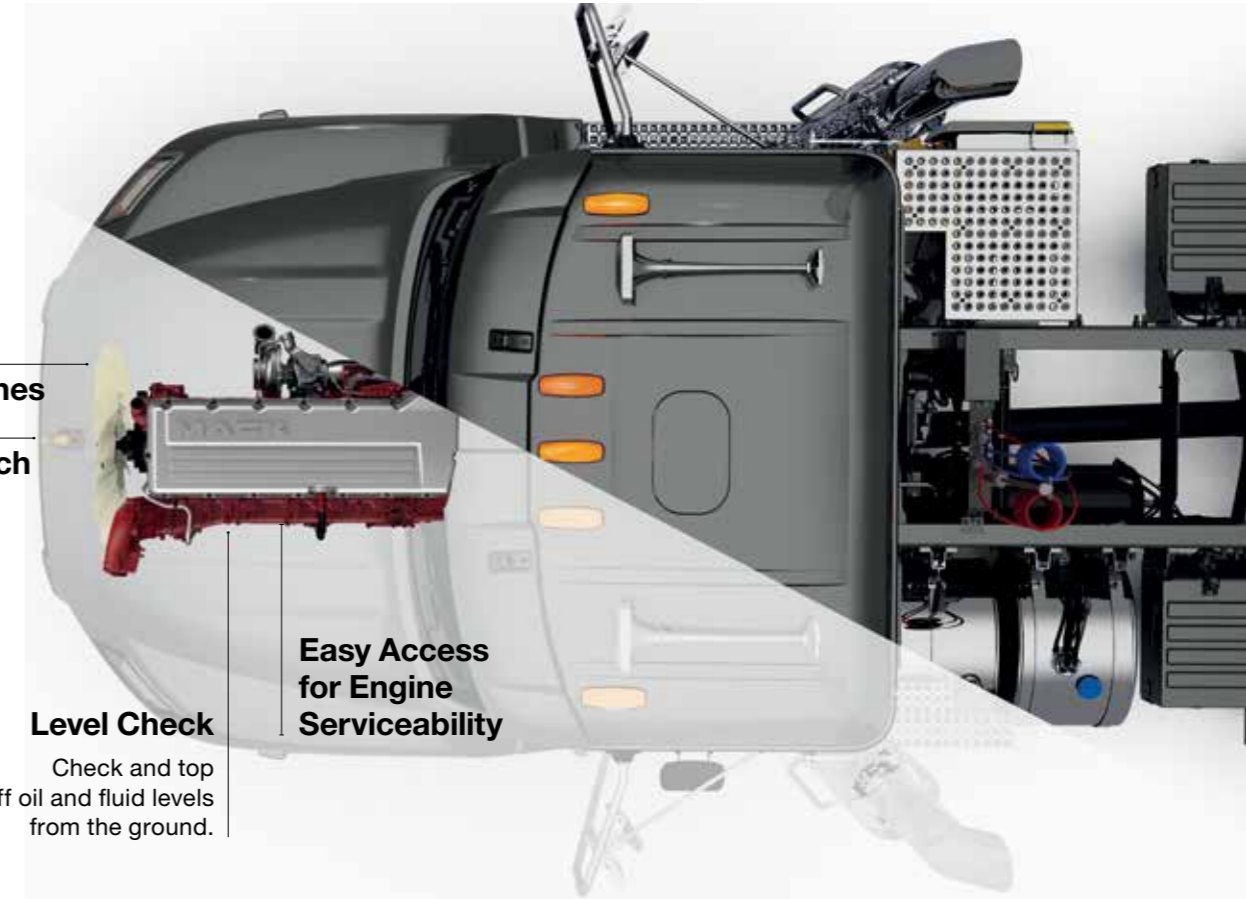

LOWER REPAIR COSTS

3-Piece Bumper

The 3 pieces can be ordered as separate replacement parts for improved serviceability.



Powered by Mack's integrated powertrain.

Engineered for efficiency and performance, our all-Mack driveline is the toughest in the game. Bar none.

Mack MP® Engines

With horsepower, torque and superior fuel economy, Mack's MP® engines conquer the highway, kilometre after kilometre.

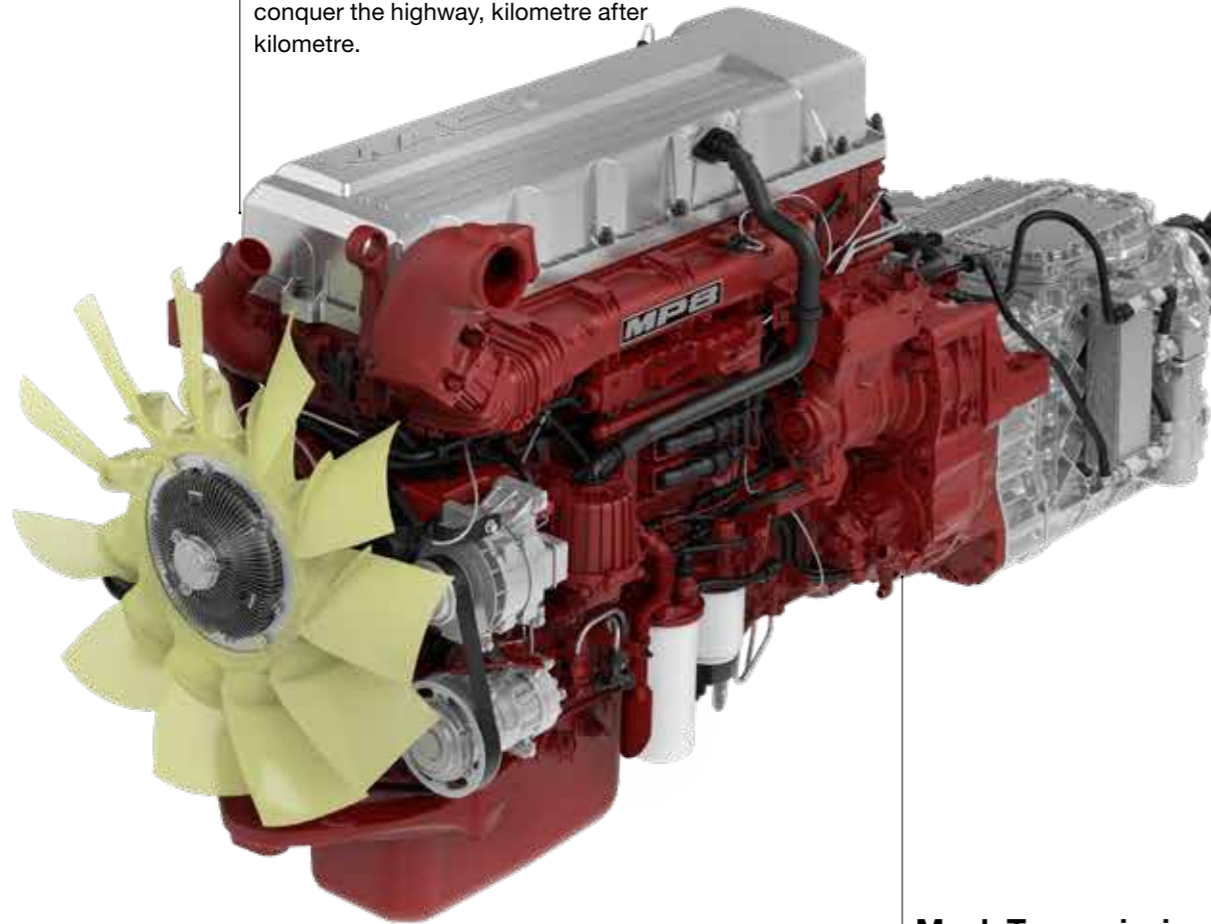

Mack Transmissions

Mack's transmissions are designed and built to perform at the highest level in the most demanding conditions, just like the rest of the truck.

Mack Suspensions

Engineered to be lighter and stronger, for enhanced reliability and outstanding performance. Mack has developed two types of suspensions for specific purposes:

Spring

The Mack Inverted Leaf heavy duty suspension is specifically designed for outstanding durability and minimal maintenance.

Air-Suspended

The Mack Air Ride is designed for fast and heavy long-haul transportation on or off roads and offers the driver considerable comfort both with a laden and an un-laden truck.



Mack Axles

Built to handle long hauls and the relentless punishment of the road.

mDRIVE™ HD & mDRIVE™ XHD

Mack's mDRIVE automated manual transmission is now available with an extended range of deep reduction gears - the Heavy Duty (HD) 13 speed or Xtreme Heavy Duty (XHD) 14 speed - plus additional multi-speed reverse gears.



Precision Handling

The mDRIVE HD or XHD allows you to slow it down for jobs that require extra precision or speed it up to take on your roughest work.



Mack's industry-leading automated manual transmission expands your driver base and reduces costs.



Smarter Hauling

mDRIVE™ continuously monitors changes in grade, acceleration, vehicle weight and more to optimize fuel economy.

Easy to Operate

Drivers can manage mDRIVE™ with just the press of a button, making it more comfortable and easier to operate, even for new drivers.

Minimal Service

Proven technology and superior design mean mDRIVE™ requires minimal service, significantly reducing maintenance costs and downtime.



Designed for the driver.

COMMAND THE ROAD

Anthem's intuitive instrument panel and steering wheel give drivers total confidence and control in the cockpit.

UTILITY FROM TOP TO BOTTOM

Configure Anthem's best-in-class storage for as much or as little as you need to store.

COMFORT FOR THE LONG HAUL

A spacious interior and American craftsmanship give drivers the comfort they need to feel at home.

Control at your fingertips and information at a glance.

The Mack Anthem's controls are designed to make operation easy, safe and comfortable. While the instrument panel brings important information to the forefront, keeping it clear and readable so drivers can stay focused on the road ahead.

D-Panel Gauges

Customize the dash with 4 optional auxiliary gauges.

mDRIVE™ Controls

Intuitive placement gives drivers comfortable access without taking eyes off the road.

Rocker Switches

New larger, robust rocker switches are laser etched to be readable for life.

Mack® Co-Pilot™

5" full-color digital display provides enhanced visibility and simpler navigation without distractions. Constant truck monitoring and Pre-Trip Assistant, including one-person Exterior Light Inspection, help keep an eye out for potential issues before they become real ones.

Digital-Analog Gauges

Solid dial hands with the precision of digital instruments.

Illuminated Controls

Keep eyes on the road with familiar, automotive-style controls.

Flat-Bottom Steering Wheel

An industry-first, allowing more room and clearance for entry or exit. Add to that a racecar-style grip, enhanced dash visibility and clipboard-friendly surface for better control and maximum comfort.

Power Window, Lock and Mirror Controls

Provide more comfort and control than manual windows.

Light Control Module

Runs all exterior lights from one place with an automotive feel.

Right Stalk

Manages engine brake and Co-Pilot™.

Left Stalk

Manages high beams, self-canceling turn signals and wipers.

Unmatched comfort.

Anthem's spacious cab, stand up sleeper and premium materials create an interior that's as comfortable as it is functional.

MACK

Mack-Exclusive Seats

To ensure the driver is well supported on their journey, we partnered with ISRI to provide high quality seats that are both comfortable and durable enough to take on daily wear and tear.

- Air suspension
- 2 Upholstery levels



2,120mm

1,828mm

Anthem's generous ceiling height lets drivers stand up in the cab and walk right through to the sleeper. Driver model shown at 5'10".

artist impression only



Sleeper Fan



Sleeper Control Panel



Sleeper Lighting

Home away from home.

We built the Mack Anthem 36-inch Stand Up Sleeper with 35% more space to give drivers plenty of room to get comfortable, rest well and stay focused on the road.



Sleeper Mattress



Sleeper Windows

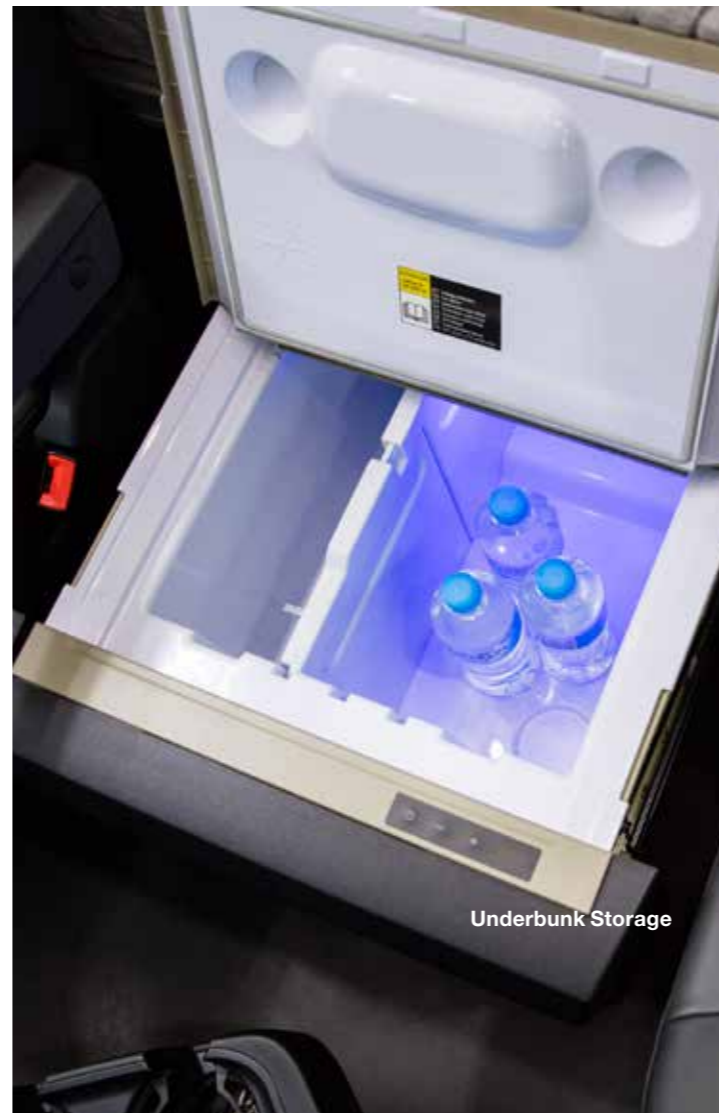

Underbunk Storage

SLEEPER FAN

An oscillating fan is installed on the rear wall to provide you with light air flow in the sleeper.

SLEEPER CONTROL PANEL

See the time, access 12V power outlets, USB ports and interior lighting from one convenient panel. Store your mobile device in the fabric pocket while you charge it.

SLEEPER LIGHTING

Bunk task light, reading lights and overhead lights are all bright, long-lasting LED.

SLEEPER WINDOWS

Sleeper windows feature self-contained bug screen and built-in shades that block 100% of light. The screened windows tilt out to let air in and keep rain out. Or use the oscillating fan.

SLEEPER MATTRESS

Designed with pocket springs, the premium quality mattress not only feels soft but provides consistent, total body support for a comfortable night's sleep.

UNDERBUNK STORAGE

Easy access to locker boxes from inside the cab. Optional 36L underbunk fridge/freezer for convenient storage of food and beverage.



Side Overhead Cabinets

Deep storage areas above the driver and passenger doors create a secure space for gear in the 36-inch Stand Up Sleeper.

Front Overhead Console

Generous storage with tough materials and interior LED light controls.

Safe, secure storage.

Even on rough roads, electronics, drinks and gear stay in place with Anthem's industry-leading storage.

Additional Storage

Oversized cup holders fit large drinks and there's room for keys, devices and more in the easy-to-clean unit.

With Mack Uptime Solutions, it's uptime in real time.

Mack's uptime and productivity solutions, combines intelligent software, driver assist technologies and more to help you keep your trucks—and your business—moving forward.



CONNECTED SUPPORT

Your trucks are only profitable when they're on the road and on the job. Maximize your uptime with intelligent maintenance systems and time-saving repair processes.

Preventive Maintenance

Keep your trucks in top shape with a Mack Optimised Service Plan that creates a tailored service schedule that matches the usage and kilometres of your vehicle, so we can repair or replace components before it impacts your business.



CONNECTED BUSINESS

To succeed in the modern trucking industry you need to run a modern trucking company. Drive profitability and gain insights at every turn with Mack's fleet management systems.

Mack Telematics®

Advanced fleet management system that monitors driver and truck performance with real-time analysis and top-line reporting to help you improve business operations.

Mack Fuel Solutions

The coaching, advice and technology to cut your fuel costs.

Fuel Tax Credits

Helping you get the most out of your Fuel Tax Credit claim, this monthly report saves you time, reduces errors and ensures you always claim your full entitlement and have evidence to substantiate the claim.



CONNECTED DRIVING

The trucking business can be demanding on our trucks and our drivers. Protect your fleet with our most advanced safety system, providing driver assist technologies to give you peace of mind.

Mack Predictive Cruise

Proprietary Mack technology that stores hilly terrain in GPS data to optimise engine speed and fuel efficiency on saved routes.

Bendix Wingman Fusion

Driver assist and safety technology combining radar, camera and brakes from the leader in collision mitigation.

Collision Avoidance

Automatically alerts the driver and, if needed, applies the foundation brakes to mitigate or prevent a potential collision with a forward moving vehicle or stationary object.

Roll Stability

The Bendix® ESP® full-stability system helps drivers mitigate rollovers and loss-of-control in situations on wet and dry roadways through advanced sensors and throttle and braking interventions.

Connected Driving



Connected Business



Connected Support

WE'RE ON CALL TO KEEP YOU ON THE ROAD

Mack Action Service is a breakdown coordination service that links you to our entire dealer network, to get you moving again in the shortest possible time.

WE'VE GOT YOU COVERED

As an addition to our Ultimate service agreement, Mack Ultimate Uptime means if you have a breakdown, with one call to Mack we'll be on the job so you can get back to doing yours.

ADDED RELIABILITY

For premium performance, reliability and full warranty protection, nothing comes close to Mack Genuine Parts quality.

THE ULTIMATE CONNECTION BETWEEN MAN AND MACHINE

Our Driver Development courses are designed for different applications, we deliver industry-leading instruction that helps drivers learn techniques to optimise fuel efficiency and reduce running costs.



Support at every turn.

Over 80 authorised dealers, parts and service locations across Australia and New Zealand. When you need assistance, the Mack network is ready to deliver.

LARGEST DEALER NETWORK

The Mack Dealer Network is committed to quick, quality service. Mack's large dealer network offers trained technicians, more accurate diagnostics and improved communication that gets you back on the road. No matter where the job takes you, you can trust Australia and New Zealand's largest dealer network has got you covered.



SERVICE AGREEMENTS

When you're running a business, there's a lot to keep your eye on. With Mack Service Agreements, you'll have one less thing to worry about. Well planned services, timed and tailored to your operations, and genuine Mack parts mean your fleet will spend less time in the workshop and more time on the job. With one monthly payment, you'll have improved cash flow and the reassurance that your trucks are in top condition.



Your business. On your terms.

You know your business better than anyone.
So Mack Business Services offers you
dedicated experts and flexible terms to help
you get into a Mack and get out on the road.

MACK FINANCIAL SERVICES

Mack offers comprehensive financial services that include customised loans, flexible payment plans, competitive rates and outstanding service that works for you, so you can build your business.

WARRANTY AND PROTECTION PLANS

Running a business gives you more than enough to think about. So we give you a 12 month unlimited kilometre Mack coverage, with extended driveline coverage options available.



1300 MYMACK
MackTrucks.com.au

-  facebook.com/MackTrucksAustralia
-  instagram.com/MackTrucks_Australia
-  linkedin.com/company/Mack-Trucks-Australia
-  youtube.com/MackAustralia

©2020 Mack Trucks.